

UNLESS OTHERWISE SPECIFIED, DIMENSIONS ARE IN MM. DIMENSIONS W/O TOLERANCES ISO2768-mK AS FOLLOWS. SURFACES ISO1302. TOLERANCES ARE NOT CUMULATIVE.

LINEAR DIMENSIONS							
0.5 to 3	>3 to 6	>6 to 30	>30 to 120	>120 to 400	>400 to 1000	>1000 to 2000	>2000 to 4000
±0.1	±0.1	±0.2	±0.3	±0.5	±0.8	±1.2	±2

ANGULAR DIMENSIONS					BEND DIRECTION	
to 10	>10 to 50	>50 to 120	>120 to 400	>400	↙ ↗	BEND OUT
±1°	±0°'30"	±0°'20"	±0°'10"	±0°'5"	↘ ↕	BEND IN

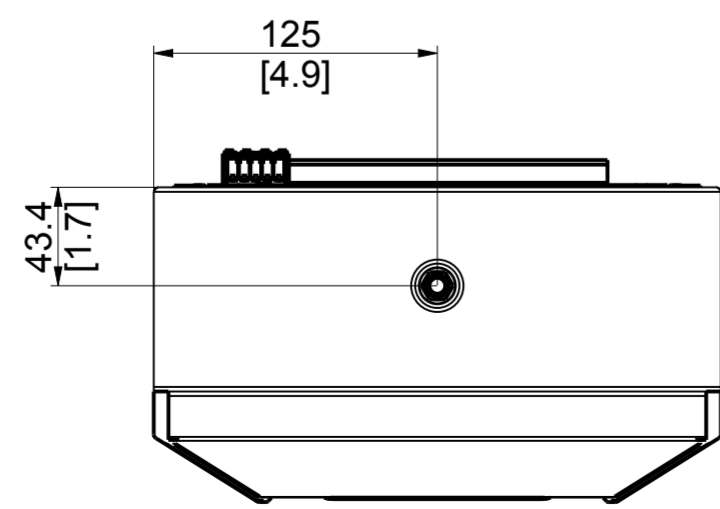
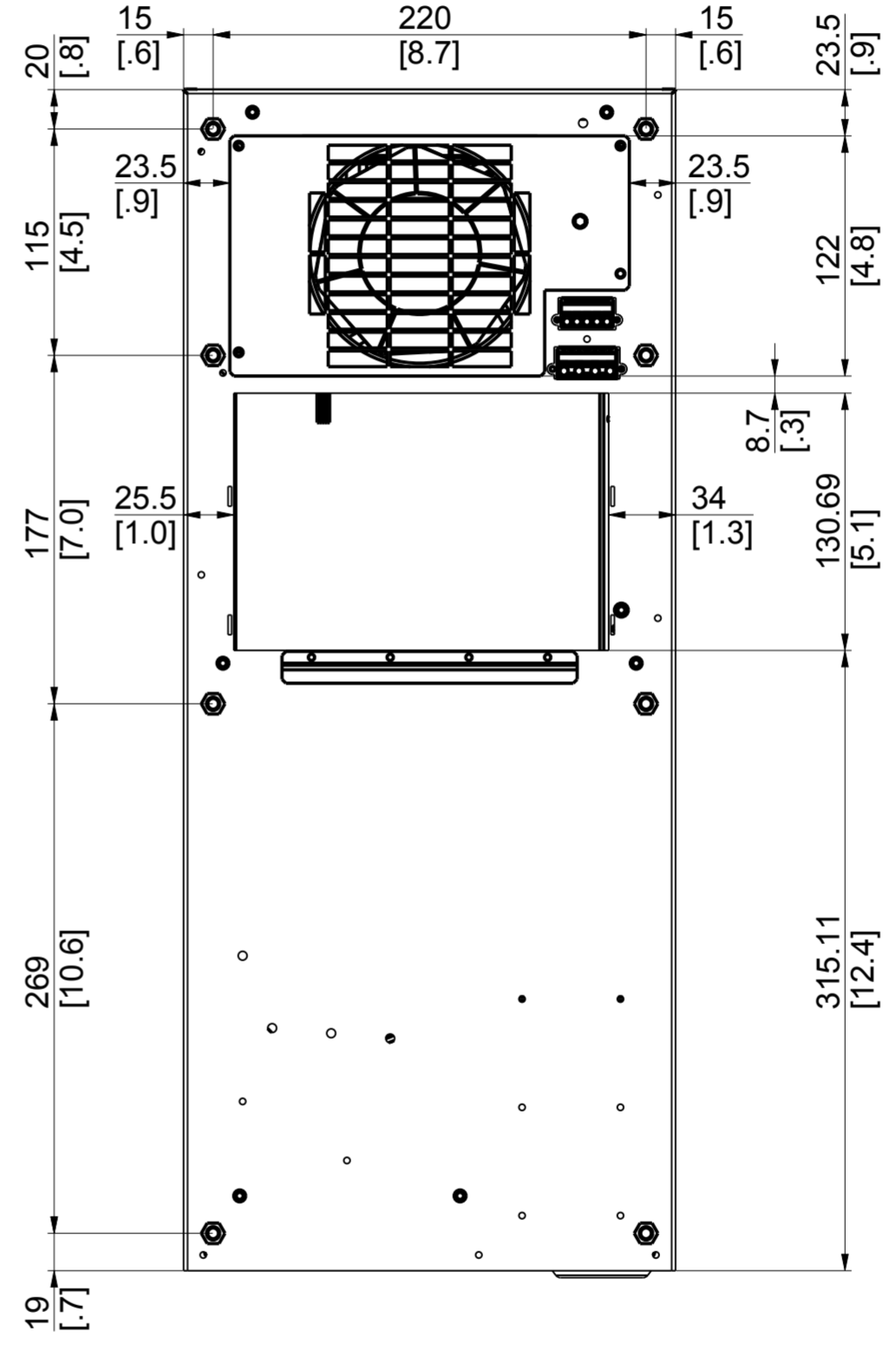
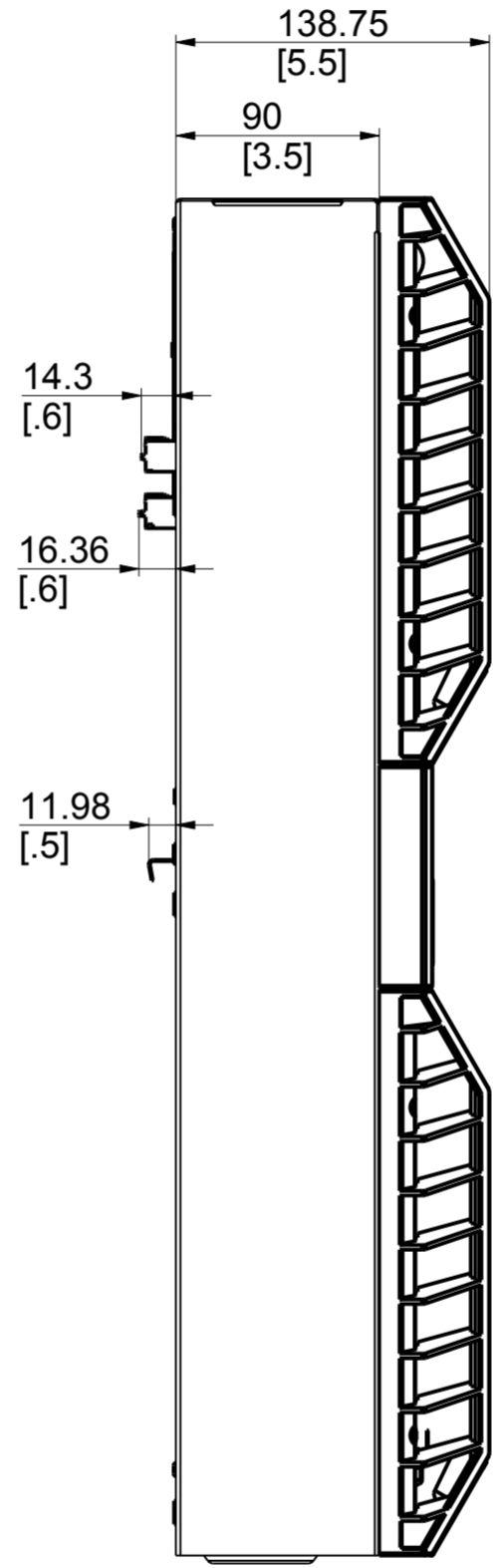
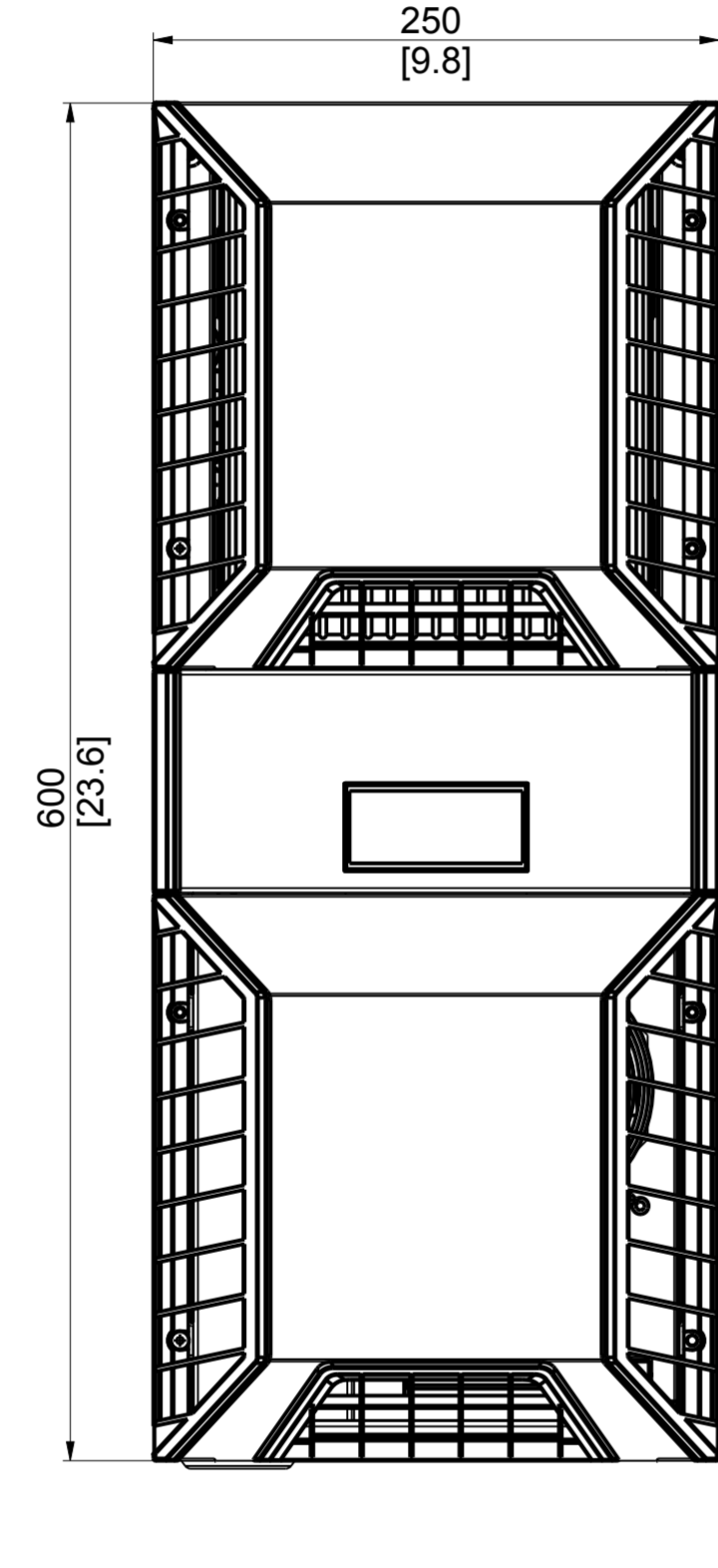
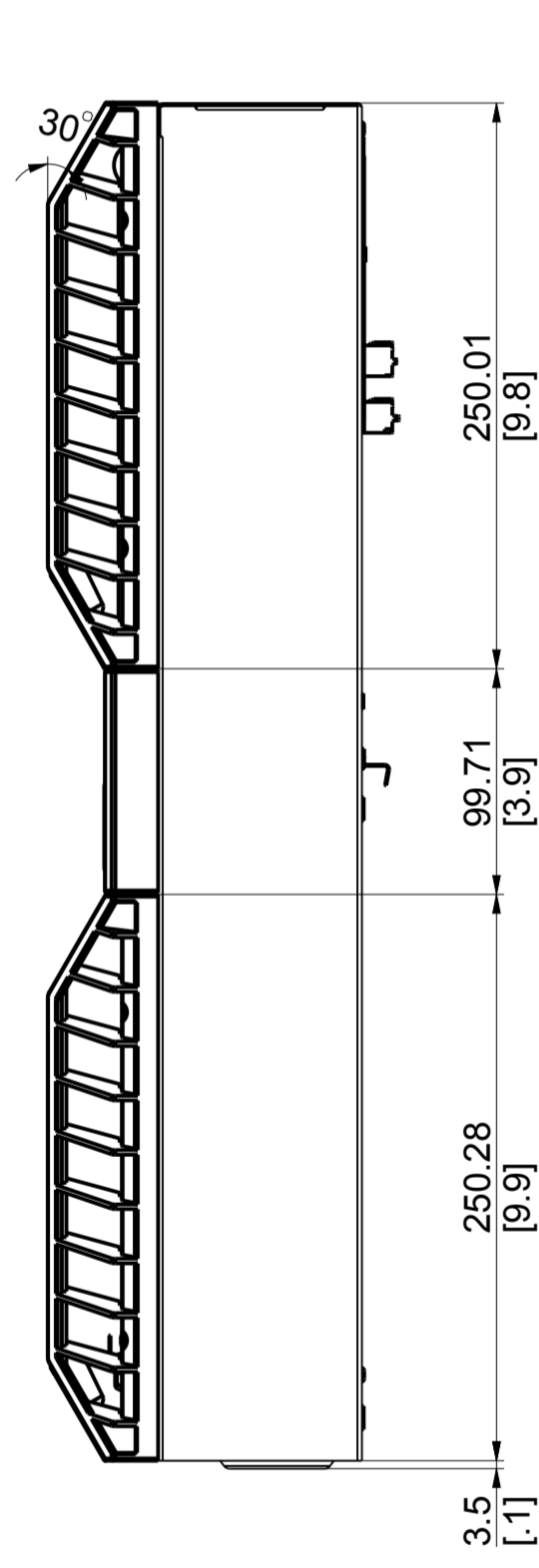
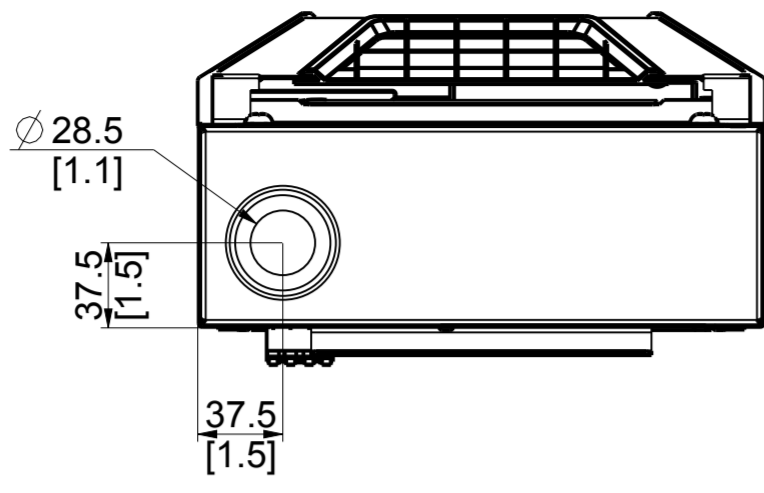

NOTES:
 1. THIS IS A PRO/ENGINEER PARAMETRIC DRAWING. ANY CHANGES MUST BE WITHIN PRO/INTRALINK.
 2. REMOVE ALL BURRS AND SHARP EDGES.

REV	BY	DATE	DESCRIPTION
1.4	BG	29.01.20	Added two mounting points
1.3	BG	18.12.19	Updated views
1.2	BG	10.10.19	Updated views & added dimensions
1.1	BG	08.02.19	Updated views

Art.no.: -
 Material: -

Air-conditioning Unit 300W/600W
 KG-8503/6 sheet metal covers

Designed:	G.Zammit	22/06/2018	FIRST ANGLE PROJECTION	SCALE
Drawn:	B.Galea	02.07.2018	SHEET	1 of 2
Checked:	G.Zammit	Approved: G.Zammit	ISSUE	1.4
				SIZE
				A2

45493	DRAWING	1.4	Work In Progress
KG-8506_COMPLETE	ASSEM	2.8	Work In Progress
PRO/E_FILENAME	FILE TYPE	REV	RELEASE



↗ ↑ BEND OUT
↘ ↓ BEND IN

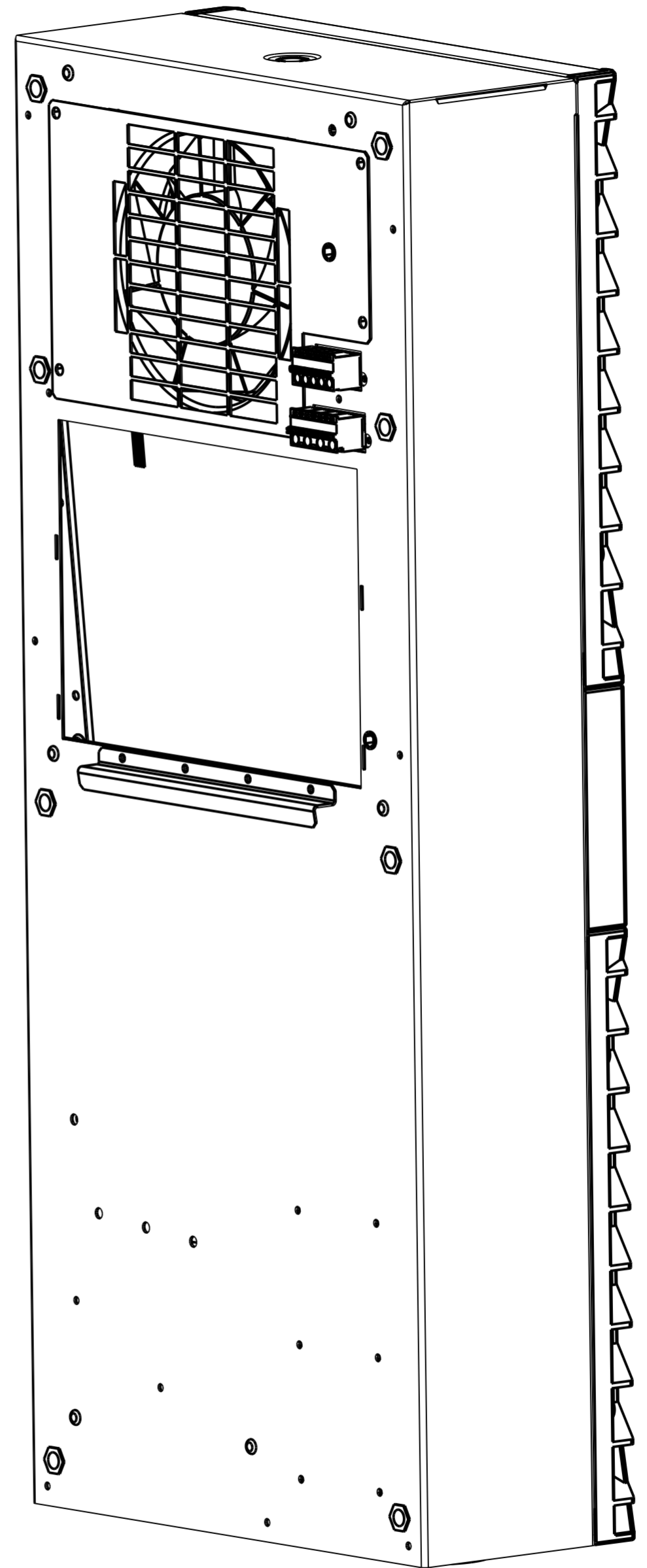
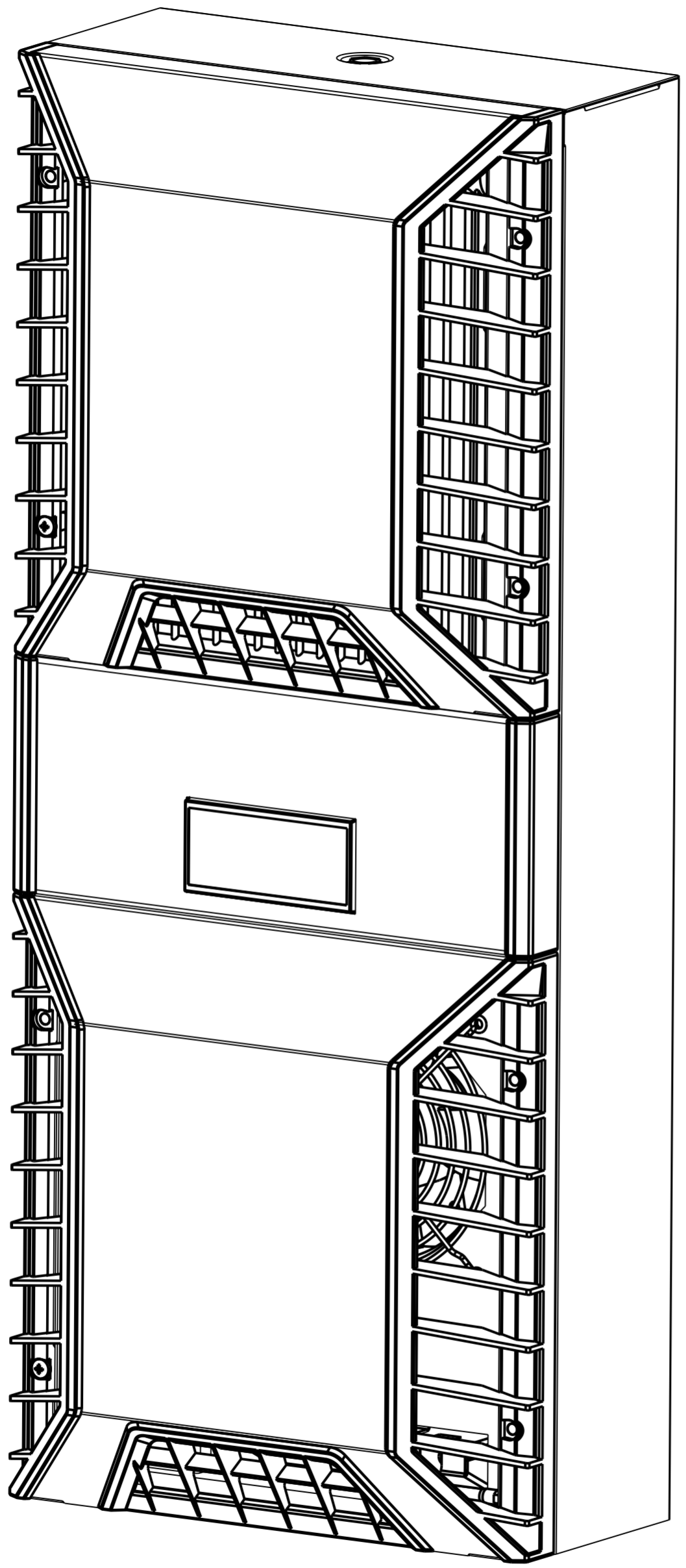

Art.no.:	596045335		
Material:	-		
Mounting Template KG-8503/6			
SHEET	SCALE	SIZE	FIRST ANGLE PROJECTION
2 of 2	0.500	A2	
45493			



45493	DRAWING	.	
KG-8506_MOUNTING_TEMPLATE	PART	2.4	Work In Progress
CREO FILENAME	FILE TYPE	REV	RELEASE